

## CONSTRUCTIVE AND FUNCTIONAL UPGRADING OPPORTUNITIES FOR THE HEAT SECTION FROM UNIVERSITY OF ORADEA

**Cercetător științific III Cristian VANCEA**, Centrul de cercetări Geotermale Universitatea din Oradea, România

**Profesor Doctor Inginer Mircea GORDAN**, Facultatea de Inginerie Electrică și Tehnologia Informației Universitatea din Oradea, România

**drd. ing. Tania-Mariana POPA**, Universitatea din Oradea

**Abstract:** The paper deals with theoretical and practical considerations. The heat section of the University of Oradea ensures the efficient, thermal energy needed for the current heat users. The disadvantage is that the geothermal water temperature, out of the point, is of 50°C, temperature which is made higher, both for the reinjection and also for the discharge. It was found that although the heat exchangers were replaced on the circuit to prepare domestic hot water, electric valve regulating the flow of geothermal water is called CV3 due to large fluctuations recorded in domestic hot water consumption. If the geothermal water temperature output drops to about 30°C, should be available heat, heat that could be used for district heating and providing domestic hot water heat prospective users listed in the development plan University of Oradea, analysis that we intend to perform further.

**Keywords:** primary users, heat pump, efficiency, friendly to the environment

### 1. BENEFITS OF GEOTHERMAL HEAT PUMPS

In this paper, we suggest a different approach, different from the existing one, namely using cascaded geothermal heat pump using vapor compression. Heat pump has some notable advantages [[www.german-renewable-energy.com](http://www.german-renewable-energy.com)], such as:

- efficiency,
- friendly to the environment,
- responsibility towards the environment,

### Heating efficiency areas:

In the first case, choose a conventional heating system. This will consume 100% energy to cover the heat. In the second case, it chooses the heat pump. This will consume only 30% as much energy as to achieve the same result as the remaining energy for heating will be taken from the natural environment for free. In other words, when a conventional heating system uses an energy unit, heat pump uses only 0.3 which allows heating of financially accessible.

### Friendly to the environment:

A source of renewable and clean energy. Since the heat pump consumes less energy, it reduces such pollution resulting from the use of conventional fuels. 1 because conventional fuels are polluting emissions such as carbon dioxide, nitrogen oxides and sulfur dioxide. Nitrogen oxides and sulfur dioxide are particularly unpleasant - they are a part of the cause of acid rain and some breathing problems. These gases are carefully monitored by the European authorities. To achieve the same result, heating a house on a heat pump can reduce nitrogen oxide pollution by 70% compared with a conventional fuel-based boiler. If sulfur dioxide, reducing pollution that substance can

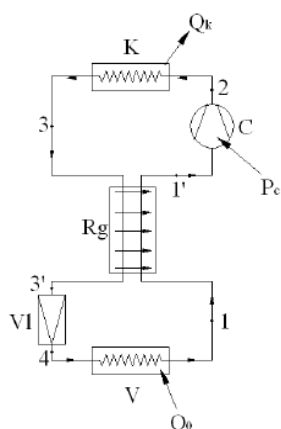

**Fig 1.** Functional diagram of a heat pump  
 $\dot{Q}_0$  - Amount of heat taken, V - evaporator;  
 Rg - regenerative; C - Compressor,  $\dot{Q}_k$   
 thermal capacity of the pump; K - condenser;  
 VI - rolled valve.

be up to 30%. Carbon dioxide is a gas and "important" and is the subject of the third

**Responsibility towards the environment:**

An effective method to combat the greenhouse effect Carbon dioxide is one of the gases responsible for the "greenhouse effect". This is already well known today, namely that increasing greenhouse effect climate changes our planet. You need to be taken in this regard and still very urgent. Kyoto International Conference triggered the alarm and set targets for reducing gases for various countries involved. Heat pump is fully part of the policy to combat the greenhouse effect - Instead, it is an ally in this fight. For example: in France, where heat 1kWh resulting product gas equivalent of 370g of carbon dioxide, heat 1kWh same product with a heat pump produces only 60g of carbon dioxide, ie 6 times less!

Examples of notable advantages for the use of heat pump (kWh costs of various systems to produce heat, heat housing costs, investment costs, total costs of heating after 20 years) are given by: [WWW . German-renewable-energy.com]

**2. SIZING CALCULATIONS**

The academic campus includes a series of buildings with a developed area of approximately 70,000 m<sup>2</sup> (built Vcl.tot volume = 155,000 m<sup>3</sup>). Some existing buildings may be considered old. The total area of these old buildings is approximately 32,000 m<sup>2</sup> (Vcl.vechi = 125,000 m<sup>3</sup>) and area of buildings constructed in November (Vcl.noi = 30,000 m<sup>3</sup>) is 7600 m<sup>2</sup>. In these buildings are furnished educational facilities, teaching and research laboratories, research and design offices, sports halls, administrative offices, two student hostels, university canteen, etc.

In the extension plan of the University of Oradea we intend, among other things, to build a new library, with a developed area of 5900 m<sup>2</sup> (Vcl.bibl . = 32,000 m<sup>3</sup>), some student hostels with a total capacity of 400 seats, with an area undertaken by 9900 m<sup>2</sup> (Vcl.cămin . = 30,000 m<sup>3</sup>), a swimming pool with geothermal water, a greenhouse designed for the students from the Faculty of Horticulture.

According to DIN 4701 on conditions to be met by heated buildings present, the values of thermal characteristics of unit: 2 qu = 45-60 W / m<sup>2</sup> (0,43-0,57 kcal/m<sup>3</sup>hK) new construction (regulation of 2002) qu = 50-60 W / m<sup>2</sup> (0,48-0,57 kcal/m<sup>3</sup>hK) new construction (regulation 1995) qu = 70-90 W / m<sup>2</sup> (0,67-0,86 kcal/m<sup>3</sup>hK) construction completed before 1995 qu = 120 W / sqm (1.15 kcal/m<sup>3</sup>hK) old buildings made without regulations

**Primary users**

For the primary users here are presented, the next heating calculations, based on the equations of heat transfer and thermal balance. The calculations were made in detail, both for the primary users and for the secondary ones, being obtained yhe next results: total volume: Vcl.tot = 155000 m<sup>3</sup> efficient hollow brick walls (37.5 cm thick), wooden double glazing; feature coupled thermal unit: air temperature in rooms: outdoor temperature calculation: heating period: 172 days a year (15/10 ÷ 15 / 4)

**Total hourly heat consumption for heating (power required):**

$$Q_{inc.tot.1}^h = Q_{inc}^h + Q_{vent} = 1,15 \cdot Q_{inc.tot}^h =$$

$$= 1,15 \cdot q_u \cdot V_{cl.tot} \cdot (t_i - t_e) = 4.000.000 \text{ kcal} / h$$

(4.650 kW)

Temperature Round trip for secondary agent is chosen from 70 ° C or 40 ° C, the required flow of secondary agent is:

$$\dot{m}_{sec.1} = \frac{Q_{inc.tot.1}^h}{c \cdot (t_{sies} - t_{sin})} = \frac{4.000.000}{1000 \cdot (70 - 40)} =$$

$$= 135 \text{ m}^3 / h = 37,5 \text{ l} / s$$

Temperature Round trip geothermal water is choose 85 ° C and 50 ° C, the required flow of geothermal water is:

$$\dot{m}_{prm.1} = \frac{Q_{inc.tot.1}^h}{c \cdot (t_{sies} - t_{sin})} = \frac{4.000.000}{1000 \cdot (85 - 50)} =$$

$$= 115 \text{ m}^3 / h = 32 \text{ l} / s$$

- geothermal water temperature: 85 ° C
- for heating circuit:

- Primary agent: □ geothermal water flow: 115 m<sup>3</sup> / h (32 l / s ) □ temperatures (round trip): 85 ° / 50 ° C □ pressure (round trip): 2.5 / 0.8 bar

- Secondary Agent: □ hot water flow: 135 m<sup>3</sup> / h (37.5 l / s) □ temperatures (round

trip): 70 ° / 40 ° C □ pressure (round trip): 3,5 / 1,5 bar

### Secondary users of geothermal energy

In the extension plan of the University of Oradea we intend, among other things, to build a new library, with a developed area of 5900 m<sup>2</sup> (Vcl.bibl . = 32,000 m<sup>3</sup>), some student hostels with a total capacity of 400 seats, having a developed area of 9900 m<sup>2</sup> (30,000 . = Vcl.cămin m<sup>3</sup>), a swimming pool with geothermal water, emissions to the practice of students from the Faculty of Horticulture.

For the secondary users are presented below, thermal calculations, based on the equations of heat transfer and thermal balance. The calculations were made in detail, both for the primary users and for the secondary ones, having the next results: □ total volume: 62,000 m<sup>3</sup> = Vcl.tot efficient hollow brick walls (37.5 cm thick), wooden double glazing coupled □ feature thermal unit: □ air temperature in rooms: □ outdoor temperature calculation: □ heating period: 172 days a year (15/10 ÷ 15 / 4)

### Total hourly heat consumption for heating (power required):

$$\begin{aligned} Q_{inc.tot.2}^h &= Q_{inc}^h + Q_{vent}^h = 1,15 \cdot Q_{inc.tot}^h = \\ &= 1,15 \cdot q_u \cdot V_{cl.tot} \cdot (t_i - t_e) = \\ &= 1.150.000 \text{ kcal} / h \text{ (1.340 kW)} \end{aligned}$$

Temperature Round trip for secondary agent is chosen from 60 ° C, respectively 45 ° C, the required flow of secondary agent is:

$$\begin{aligned} \dot{m}_{sec} &= \frac{Q_{inc.tot}^h}{c \cdot (t_{sies} - t_{sin})} = \frac{1.150.000}{1000 \cdot (60 - 45)} = \\ &= 77 \text{ m}^3 / h = 21,4 \text{ l} / s \end{aligned}$$

COP ≅ 4 the required flow of geothermal water is:

$$\begin{aligned} \dot{m}_{geo.inc} &= \frac{\frac{3}{4} \cdot Q_{acm}^h}{c \cdot (t_{sies} - t_{sin})} = \frac{0,75 \cdot 1.150.000}{1000 \cdot (50 - 10)} = \\ &= 22 \text{ m}^3 / h = 6,1 \text{ l} / s \end{aligned}$$

Taking the value of a heat pump, geothermal water flow required is total hourly heat consumption for cooking water domestic hot (power required): □ average domestic hot water needs: 6+15 = 23m<sup>3</sup> / h □ required for domestic hot water temperature: 50 ° C water temperature □ supply: 10 ° C. Total hourly

heat consumption for domestic hot water (power required):

$$\begin{aligned} Q_{acm}^h &= \dot{m}_{acm} \cdot c \cdot (t_e - t_i) = 23 \cdot 1000 \cdot \\ (50 - 10) &= 920.000 \text{ kcal} / h \text{ (1.070 kW)} \end{aligned}$$

Considering the value of a heat pump, geothermal water flow required is COP ≅ 4 temperature geothermal water discharge resulting from the mixture:

$$\begin{aligned} \dot{m}_{geo.acm} &= \frac{\frac{3}{4} \cdot Q_{acm}^h}{c \cdot (t_{sies} - t_{sin})} = \frac{0,75 \cdot 920.000}{1000 \cdot (50 - 10)} = \\ &= 17 \text{ m}^3 / h = 4,8 \text{ l} / s \end{aligned}$$

Thermal power still available for space heating or other domestic hot water using heat pumps is:

$$t_{geo.dev} = \frac{70 \cdot 50 + 22 \cdot 10 + 17 \cdot 10}{109} = 35^\circ \text{C}$$

Volume of buildings that can be heated: built area available:

$$\begin{aligned} \dot{Q}_{disp}^h &= \dot{m}_{geo.tot} \cdot c \cdot \Delta t = 15 \cdot 1000 \cdot (35 - 10) = \\ &= 2.875.000 \text{ kcal} / h \text{ (4.700 kW)} \end{aligned}$$

Volume of buildings that can be heated:

$$\begin{aligned} V_{disp} &= \frac{\dot{Q}_{disp}^h}{1,15 \cdot q_u \cdot (t_{int} - t_{ext})} = \frac{2875000}{1,15 \cdot 0,5 \cdot 32} = \\ &= 150.000 \text{ m}^3 \end{aligned}$$

Built surface available:

$$S_{disp} = \frac{V_{disp}}{H} = 50.000 \text{ m}^2$$

Main parameters of the heating plants are: □ installed capacity 6,000,000 kcal / h (7000 kW); □ Built to be heated volume: 217,000 m<sup>3</sup>; □ domestic hot water flow 23 m<sup>3</sup> / h; □ annual amount of heat delivered for space heating: 21.000 Gcal; □ annually for the amount of heat delivered. domestic hot water: 8600 Gcal; □ hourly consumption of geothermal water: 115 m<sup>3</sup> / h (32 l / s) □ annual consumption of geothermal water: 525,000 m<sup>3</sup>; □ geothermal water discharge temperature: 35 ° C. □ power available for heating using heat pumps: 2.875.000kcal / h

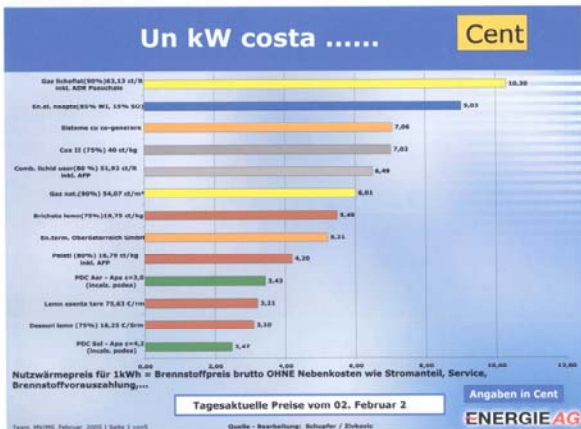

Fig 2. The cost of heating a house of 175m<sup>2</sup> with various systems to produce heat

**Calculation of heat pump  
Operation heat pump**

The operating system of a heat pump is similar to the operating system of a refrigerator.

In the case of the refrigerator, the refrigerant evaporator removes the heat through the condenser, and then it is transferred into the room.

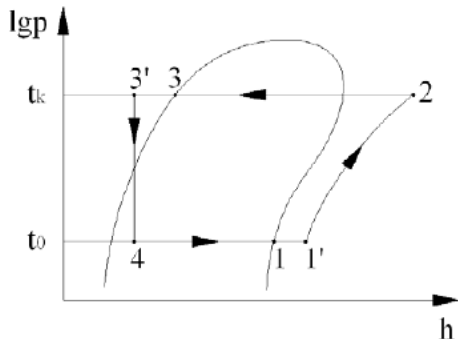

Fig 3. Work processes in the diagram LGP-h. t<sub>0</sub> - temperature vapor tk - Dewpoint 1-1 - vapor overheat 1 - 2 - vapor compression process 2 - 3 - condensing vapor 3 - 3 - sub-cooling liquid 3 - 4 - the process of rolling.

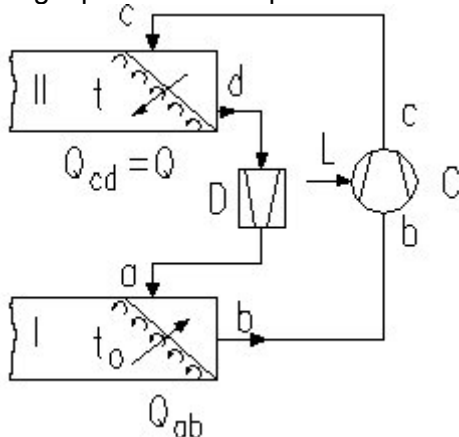

Fig. 4. The principle scheme of heat pump

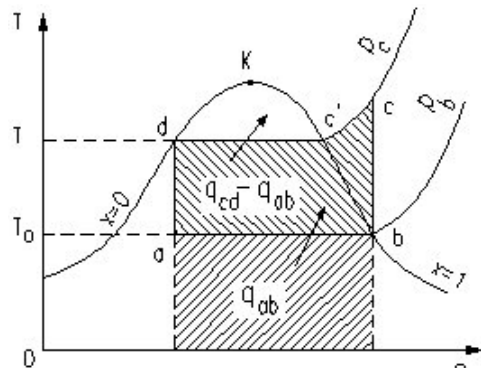

Fig 5. Theoretical cycle of a heat pump

In the case of the heat pump, the heat is taken from the environment (soil, water, air) and led to the heater. The heat circuit cooling unit is made according to physical laws. Agency work, a liquid has reached boiling point at low temperature, it leads in a circuit and running, evaporate, compresses, condenses and rebound. The evaporator is an agent working under reduced pressure. The temperature level of environmental heat the evaporator is higher than the corresponding boiling temperature field agent working pressure. This difference in temperature leads to a heat transfer agent working on environmental and working agent boil and vaporizes. Vapors displaced from this agent are continuously withdrawing the compressor and compresses. During compression increases the vapor pressure and the temperature. The vapor reaches the compressor heat into the condenser, which is surrounded by heat. The heat temperature is lower than the condensation temperature of the agent working, so that vapors are cooled and liquefies. The heat taken in evaporator and additional electricity transferred by compression, condensation is released in the condenser and heat transfer. the working agent is recirculated through the evaporator valve rolling. Staff working at high pressure passes to the condenser, the low pressure evaporator. On entering the evaporator to reach the new pressure and initial temperature. The circuit is closed. In a subrăcitorul regenerative heat exchange occurs between the vapor produced in evaporator and the liquid resulting from condensation. Following the exchange of heat, the liquid found in a high temperature, vapor heat yields suffered a subrăcire. Vapor due to the fact that they receive an additional quantity of heat, is overheating.

**Secondary users of geothermal energy using heat pumps**

**Hourly total heat requirement for heating (power required):**

$$Q_{inc.tot.2}^h = 1.150.000 \text{ kcal} / h (1.340 \text{ kW})$$

The PDC will use 20 units of ground-water type WPF STIEBEL-EL TRON 66 in parallel or series modular 400kW four units, connected in parallel.

**Total time needed for domestic hot water heat (power required):**

$$Q_{acm}^h = \dot{m}_{acm} \cdot c \cdot (t_e - t_i) = 23 \cdot 1000 \cdot (50 - 10) = 920.000 \text{ kcal} / h (1.070 \text{ kW})$$

9 PDC will use 16 units of ground-water type WPF STIEBEL-EL TRON 66 in parallel or series modular three 400kW units, connected in parallel.

Constructive-functional parameters of ground-water type PDC WPF 66 STIEBEL-EL TRON (as Product Manufacturing Program STIEBEL-Eltron 2007-2008): - H x L x W [mm] 1160x1250x870, - weight [kg] 600, 6 - temperature cold source (solution of the probe) from -5 to 20 [degrees Celsius] - maximum temperature on lap 60 [degrees Celsius], - the required flow of cold source (the probe solution) 16.3 [m<sup>3</sup> / h] at 230 [hp] - required flow of the heating circuit (heat) 12.5 [m<sup>3</sup> / h] to 280 [hPa]; - now coupling the heating circuit and the circuit G 2 ½ cold outside source -- R410A refrigerant - the temperature of 0 [degrees C] the solution of

the probe and the temperature 35 [degrees C] the heat on Tour (W0/W35): - 66 total thermal power [kWth] - electric power absorbed 14.3 [kWel] - COP = 4.6.

Use the heat pump module in the heat section of the University of Oradea is achieved by coupling their form of "battery heat pump" modules consist of PDC connected in parallel (20 units ground-water type PDC WPF 66 STIEBEL-EL TRON or four modular units range 400kW heating system, and 16 units of type ground-water PDC WPF 66 STIEBEL-EL TRON or three units range 400kW modular system domestic hot water preparation.

**REFERENCES**

1. Abbado D., (1998), Abbado D., Orlando V., Minisale A., Tassi F., Magro G., Seghedi I., Ioane D., Szakacs AL, Coradossi N. Origin and evolution of the fluids from the Eastern Carpathians, Proceed. XVI-th Carpathian-Balkan Geological Association Congress, p 37, Viena.
2. Antal,C., Gavrilescu,O., ș.a., (2000): Utilizarea energiei geotermale. Conversia energiei geotermale în energie electrică, Editura Universității din Oradea, 2000.
3. Astrom K.J., Wittenmark B. (1984): Computer Controlled Systems. Theory and Design, Prentice Hall, 1984.
4. Athanasovici, V. (1981): Termoenergetică industrială și termoficare, Editura Didactică și Pedagogică, 1981.